



Safety & Maintenance of Gates Decoking Hose

Forward

The objective of this manual is to emphasize SAFETY by providing recommended procedures for proper handling, storage, use and maintenance of decoking hose assemblies. External inspection and field pressure testing prior to any continued service of a hose assembly is critical to ensure safe operation. These are MANDATORY PROCEDURES for applications where an assembly failure could result in serious bodily injury or severe property damage.

Scope

This procedure is a recommended practice for the storage, handling, operations, testing, and inspection of Decoking hose assemblies (See Figure 1).

Warning

A failure of a Decoking hose in service may result in serious bodily injury or severe property damage.

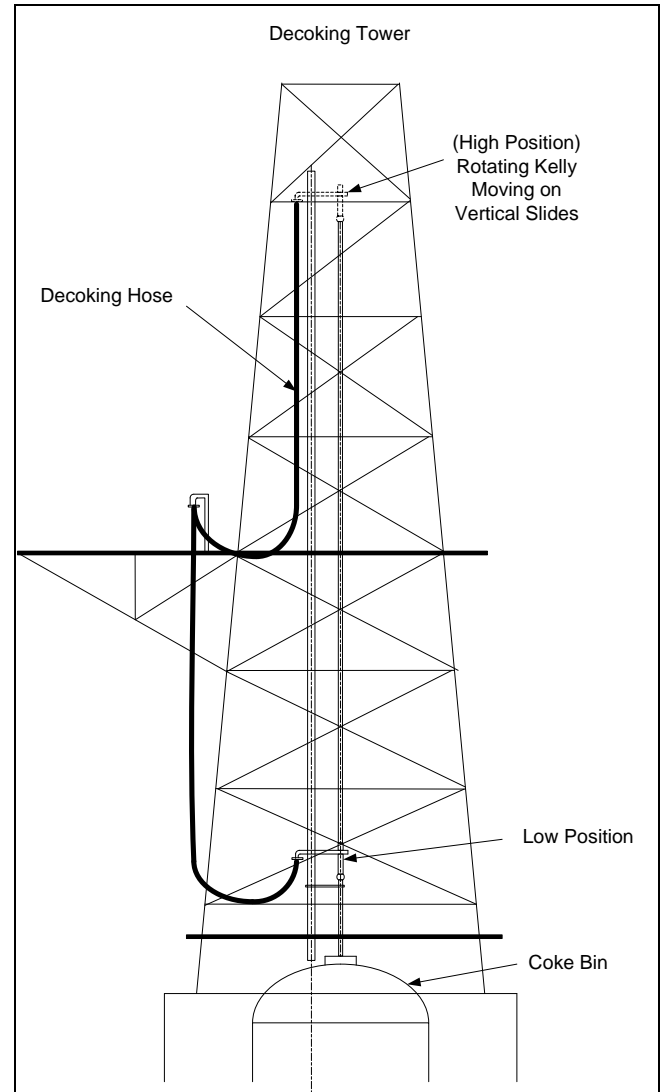

Figure 1



Safety & Maintenance of Gates Decoking Hose

Storage

1. Completely drain hose assembly before placing in storage.
2. Whenever feasible, store hose in original shipping crate. This will provide extra protection against the deteriorating effects of solvents, corrosive liquids, ozone, and sunlight. Hose should be stored so coils are in a horizontal plane.
3. Certain rodents and insects can damage hose. Adequate protection from them should be provided too.
4. The ideal temperature for storing hose ranges from 50°F (10°C) to 70°F (21°C) with a maximum limit of 100 F (38°C). If stored below 32 F (0°C), hose will become stiff and will require warming before being placed in service. Hose should not be stored near sources of heat, such as radiators or base heaters.
5. To avoid adverse affects of high ozone concentrations, hose should not be stored near electrical equipment that may generate ozone or be stored for any lengthy period in geographical areas with high concentrations of ozone. Exposure to sunlight, direct, reflected or even through windows should be avoided.
6. Do not stack hose or place anything heavy on top of it to prevent damage.

Handling

Caution: Care should be exercised to prevent mishandling. Crushing or kinking of hose can cause severe damage to reinforcement. If this occurs, remove hose from service.

1. In order to minimize the chance of kinking, hose should be preferably be removed from its crate by hand, laid out in a straight line, and then lifted by means of a catline attached near one end of hose.
2. Hose assemblies should never be lifted by the safety clamp and chain. The assembly should always be lifted by the lift eye clamps (see Figures 2 & 3).
3. Attachment of a set of lift eye clamps to the hose end coupling to safely lift and move a heavy decoking hose assembly is a necessity to avoid hose kink damage. A set of lift eye clamps can be obtained on special order (see Figure 2)

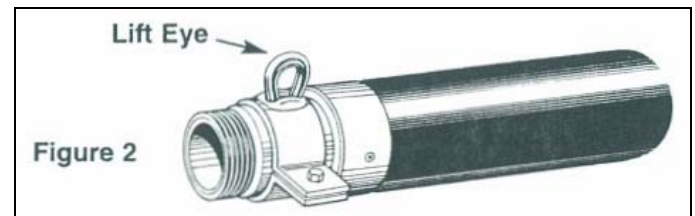



Safety & Maintenance of Gates Decoking Hose

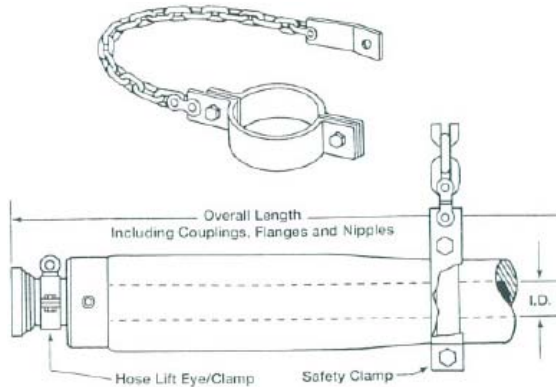

Figure 3

Operations

Caution: Care should be exercised during operation to prevent crushing or kinking of hose. Crushing or kinking can cause severe damage to cable reinforcement. If this occurs, remove hose from service and test as outlined in the “Field Test Pressure” section.

A. Application

This hose is required to convey cutting water from the fixed steel pipe work at mid drilling rig height, to the moving rotary joint at the top of the drill stem.

B. Working Temperature

Working temperature should not exceed 180°F (82°C). Temperatures encountered higher than maximum level will shorten the useful life of the hose.

C. Working Pressure

The recommended maximum working pressure for Decoking hose is shown in Table 1:

Table 1

Hose ID (In.)	Working Pressures (psi)	
	3"	5,000
3 ½"	5,000	7,500
4"	5,000	7,500

D. Drilling Cutting Water

Drilling cutter water used to break up coke and oil mixture will have phenols present up to 15 PPM concentration levels.

E. Twisting

Hose should not be intentionally back twisted. In order to prevent twisting, it is suggested that a swivel flange be installed on one end of the hose. Each length of hose has a yellow longitudinal stripe. Use this as a guide to ensure hose is installed without any twist.

F. Safety Clamps (See Figure 3)

1. All Decoking hoses 8' or longer are marked with the notation “Attach Safety Clamp Here”. Safety clamps must be installed on decoking hose prior to placing hose into service. This dimension should be 6” to 18” from the inboard end of the coupling.

2. A set of safety clamps along with lift/eye clamps can be obtained on special order. The location for attaching these safety clamps is shown by marks at each end of the assembly. Lift eye/clamps are also available. Do not use the safety clamp or chain for lifting (See Figure 3)



Safety & Maintenance of Gates Decoking Hose

Field Test Pressure

Hose assemblies subjected to abnormal abuse such as severe end pull, flattening, crushing, sharp kinking or excessive pressurization must be immediately inspected and hydro-statically tested at 1.25 times the rated working pressure. Follow steps 4 through 9 below.

Field testing of decoking hose, when required for establishing periodic safety levels of continued operation, should be conducted with these factors as a guide:

1. Check and properly attach safety clamp and chain for complete safety compliance
2. Avoid all back twist
3. Suspend hose in normal unstressed position.
4. Visually inspect hose for any external damage to hose body, end structure or couplings.
5. Raise pressure between 1,000 and 10,000 psi per minute.
6. Bleed air when using water as permissible test media.
7. Restrict duration of test pressure to a maximum of 10 minutes.
8. Do not exceed 1.25 times the working pressure when testing.

9. Conduct field testing under full responsibility of end user with SAFETY in mind.

External Inspection

1. Carefully examine hose cover prior to each use or every 30 days, whichever comes first.
2. Hose cover serves the primary function of protecting cable reinforcement from physical or environmental damage. Cover should be carefully examined to detect areas where cable reinforcement may have been damaged. Inspect hose cover for cuts, gouges, tears, and abrasion.
3. Any cuts, gouges, or tears in the cover down to, but not into cable reinforcement should be regularly inspected to ensure further deterioration does not occur. If the cable reinforcement is exposed and rust or corrosion is evident, remove hose from service.
4. Cover may show surface cracking due to prolonged exposure to sunlight or ozone. Such deterioration, as long as it does not expose the cable reinforcement, is not usually cause for removal from service.

On-The-Job Welding

CAUTION: On-the-job welding of hose assemblies is not recommended. Excessive heating from welding can cause hose damage.



Oilfield Hose Technical Note



Safety & Maintenance of Gates Decoking Hose

Warranty

Black Gold[®] decoking hoses are warranted by Gates Corporation to be free from defects in material and workmanship for twenty-four (24) months from the date of delivery to Customer. Gates will, at its option, replace or repair any merchandise proved defective in material or

workmanship, or both. In no event will Gates honor any warranty claim unless it is notified of the claim within six (6) months of the expiration of the warranty period. This shall be the sole remedy for breach of warranty.

Decoking Hose Construction

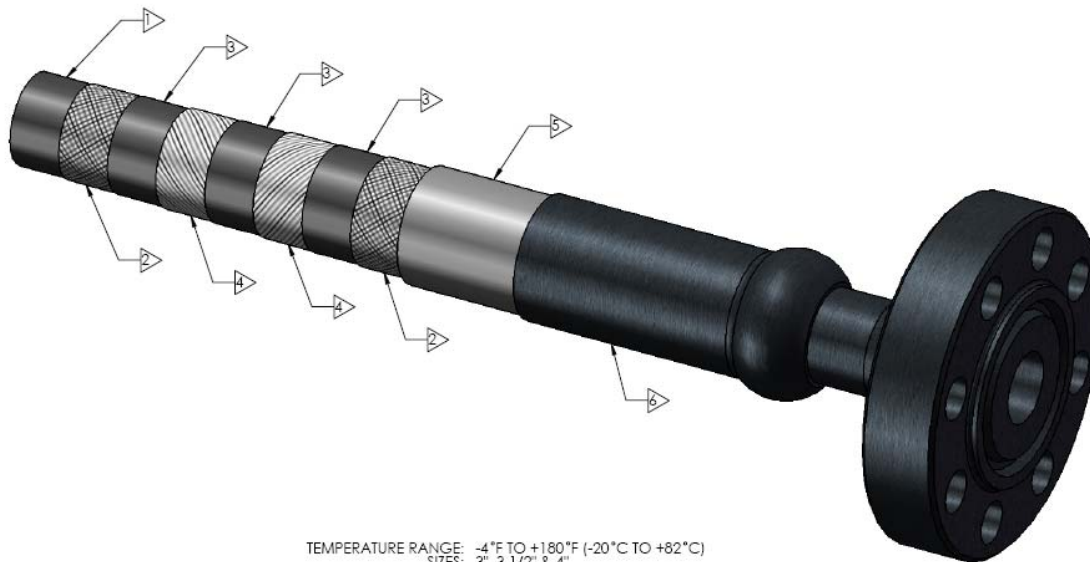

TEMPERATURE RANGE: -4°F TO +180°F (-20°C TO +82°C)
SIZES: 3", 3 1/2" & 4"

No.	Description
1	Tube – Type C3 (Modified Nitrile)
2	Textile – Multiple Layer of polyester cord over tube and under cover
3	Adhesion Layers
4	Cable – Multiple layers of High tensile brass plated steel cables
5	Cover – Type C4 (Modified Nitrile) Resistant to abrasion, corrosion, cutting, gouging, oil, and weather. One continuous longitudinal yellow transfer label. Serial number and manufacture date embossed.
6	Couplings – Swaged. Supplied with API standard flanges or equivalent